

CAST STEEL Y-STRAINER - ANSI CLASS 150

DESIGN DESCRIPTION:

- Y-PATTERN
- BOLTED COVER WITH DRAIN PLUG
- PERFORATED STAINLESS STEEL SCREEN
- FLANGED ENDS
- BUTTWELDING ENDS

APPLICABLE STANDARDS:

- SHELL WALL THICKNESS, ANSI B16.34
- PRESSURE-TEMPERATURE RATING, ANSI B16.34
- END FLANGES, ANSI B16.5
- BUTTWELDING ENDS, ANSI B16.25

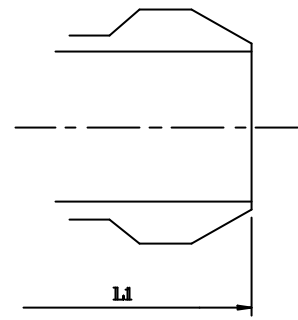
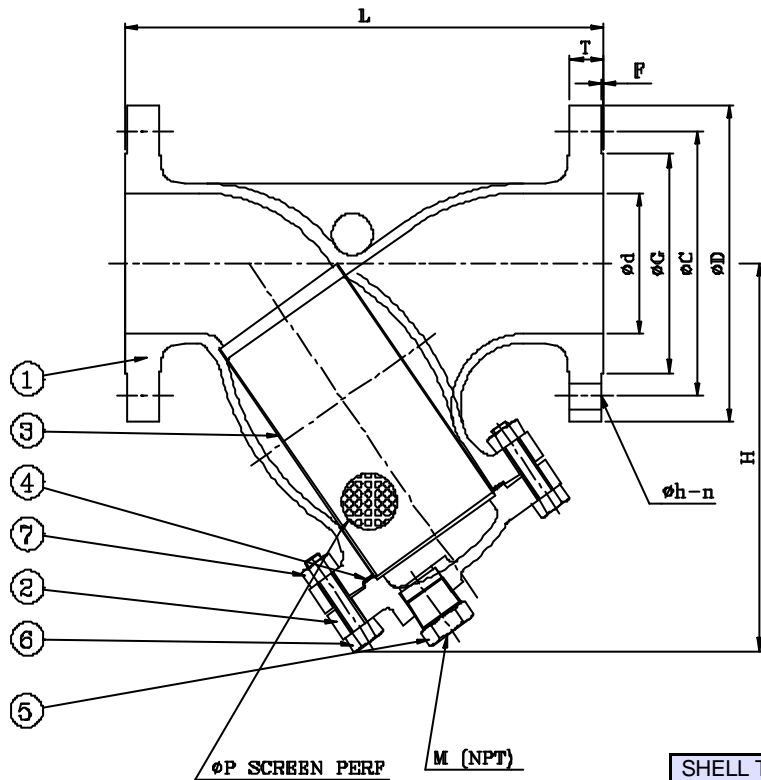

Buttwelding Ends

TEST PRESSURE TO ANSI B16.34

PSIG		
SHELL TEST (water)	SEAT TEST (water)	SEAT TEST (air)
450 (32 kg/cm ²)	—	—

PARTS AND MATERIAL (ASTM)

NO.	PARTS NAME	MATERIALS		
		WCB	LCB	WC6
1	Body	A216-WCB	A352-LCB	A217-WC6
2	Cover	A216-WCB	A352-LCB	A217-WC6
3	Screen	A240-304		
4	Gasket	Grafoil+316 Sheet		
5	Plug	A276-304		
6	Cover Bolt	A193-B7		
7	Cover Bolt Nut	A194-2H		

OTHER MATERIALS ARE AVAILABLE UPON REQUEST.

DIMENSION TABLE:

DN	NPS	Ød	L&L1	H	T	F	ØD	ØC	ØG	Øh	n	M	ØP	
													Oil	Steam
15	1/2	12.7	130	100.0	10.0	1.6	88.9	60.5	35.1	16.0	4	1/2	1.2	0.5
20	3/4	19.0	150	100.0	10.5	1.6	98.6	69.9	43.0	16.0	4	1/2	1.2	0.5
25	1	25.4	160	110.0	11.2	1.6	108.0	79.2	50.8	16.0	4	1/2	1.2	0.5
40	1 1/2	38.1	200	140.0	14.3	1.6	127.0	98.6	73.2	16.0	4	1/2	1.2	0.5
50	2	50.8	230	169.4	15.8	1.6	152.4	120.7	92.0	19.0	4	1/2	1.2	0.5
65	2 1/2	63.5	290	190.0	17.5	1.6	177.8	139.7	104.7	19.0	4	1/2	1.2	0.5
80	3	76.2	310	230.5	19.1	1.6	190.5	152.4	127.0	19.0	4	3/4	1.2	0.5
100	4	101.6	350	278.6	23.9	1.6	228.6	190.5	157.2	19.0	8	3/4	1.2	0.5
150	6	152.4	480	369.3	25.4	1.6	279.4	241.3	215.9	22.3	8	1	3.2	1.0
200	8	203.2	600	440.2	28.5	1.6	342.9	298.5	269.8	22.3	8	1	3.2	1.0
250	10	254.0	730	530.0	30.3	1.6	406.4	362.0	323.9	25.4	12	1	3.2	1.0
300	12	304.8	850	650.0	31.8	1.6	482.6	431.8	381.0	25.4	12	1	3.2	1.0
350	14	337.0	787.4	610.0	36.0	1.6	533.4	476.3	412.8	28.5	12	3/4	3.2	1.0